

AIR COMM SYSTEMS, INC

AIRBORNE-AUDIO

Dual Audio Mixer Panel

Installation and Operations Manual

ACS 300A-100

Revision 1.5

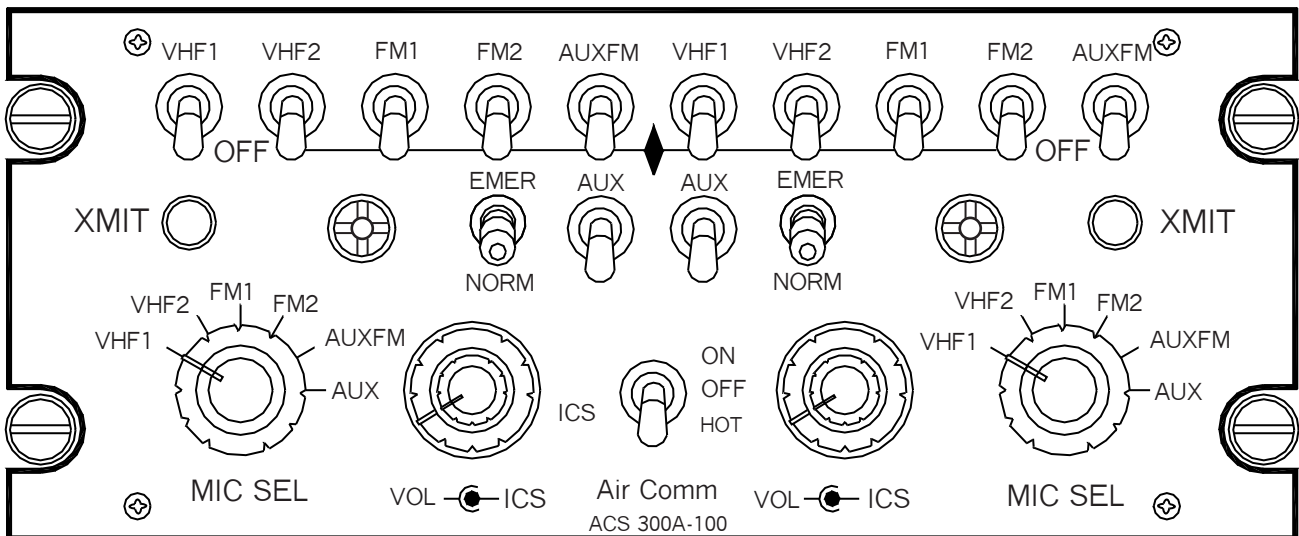

Air Comm Systems, Inc

37610 Sky Canyon Dr., Hangar 51
Murrieta, CA 92563

Ph: 951-677-0101 ~ Fx: 951-677-0701

Info@AirCommSystems.com ~ www.AirCommSystems.com

ACS 300A-100 Installation and Operations Manual

Table of Contents

■ Installation

| | |
|---------------------------------------|--------|
| Physical and Operating Specifications | Page 3 |
| Physical Dimensions | Page 4 |
| Interface Schematic | Page 5 |

■ Operation

| | |
|---------------------------------|----------|
| Front Panel Controls | Page 6-7 |
| Front Panel Controls Pictorial | Page 8 |
| Rear Panel Adjustment Pictorial | Page 8 |

■ Instructions for Continued Airworthiness

| | |
|---|--------|
| Instruction for Continued Airworthiness | Page 9 |
|---|--------|

■ Warranty Information

| | |
|----------------------|---------|
| Warranty Information | Page 10 |
|----------------------|---------|

ACS 300A-100 Installation and Operations Manual

Physical and Operating Specifications

■ Physical Specifications

SIZE: 6.31 in.(16.03 cm) W *WEIGHT:* 2.90 lb
2.62 in.(6.65 cm) H
6.78 in.(17.22 cm) D w/ connector *MOUNTING:* Dzus rail mount

CONTROLS: Panel mounted - transmit = rotary switch, audio inputs = toggle switch
volume control = dual potentiometer

ILLUMINATION: Edge lit front panel per MIL-P-7738E, type 3. Capable of connection to dimmer bus for adjustment. Transmit light indicates when unit is in transmit mode.

■ Operating Specifications

INPUTS: 6 receive audio inputs per position. 6 transmit selections per position.

DUTY CYCLE: Continuous *POWER REQUIREMENTS:* 28V DC +/- 10%

MAXIMUM OPERATING ALTITUDE: 16,500 ft.(5029 m)

OPERATING TEMPERATURE RANGE: -40 C to +85 C (operating)

-65 C to +125 C (storage)

CURRENT DRAIN: 50 mA at 28V (standby) - 1.5 A at 28V (max. signal)

AUDIO OUTPUT: Minimum 250 mW into 600 ohms

FREQUENCY RESPONSE: Within 6 db - 300-3000Hz

ICS INPUT IMPEDANCE: 600 ohms

RECEIVER INPUT IMPEDANCE: 600 ohms - matched to receiver

INPUT ISOLATION: Not less than 45 db between inputs

AUDIO MUTING: Not less than 45 db during transmit/ICS (optional)

MIC SENSITIVITY: 300 mV for rated output

DISTORTION: Less than 10% at 1000 Hz for maximum output

ACS 300A-100 Installation and Operations Manual

Physical Dimensions

Physical Dimension Outline

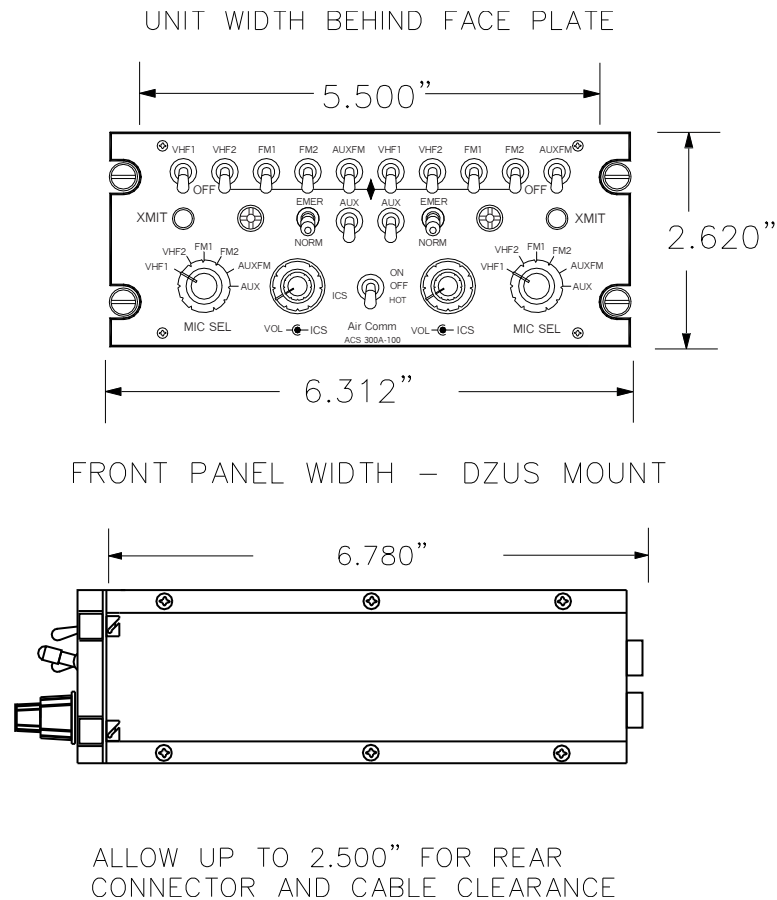

Physical Installation

The ACS 300A-100 is designed to be Dzus mounted and should be installed in the aircraft using the Installation Kit that was included with the unit. The above outline drawing of the unit with dimensions will facilitate the installation. The Installation Kit consists of the following:

- One (1) 37 pin AMP D-Subminiature female mating connector complete with crimp pins, hood, and slide lock.
- One (1) 25 pin AMP D-Subminiature female mating connector complete with crimp pins, hood, and slide lock.

The connector pin configuration of the ACS 300A-100 rear connector and the recommended wire size for the aircraft cable harness is shown on the following page.

ACS 300A-100 Installation and Operations Manual

Interface Schematic

■ Connector Pin-out

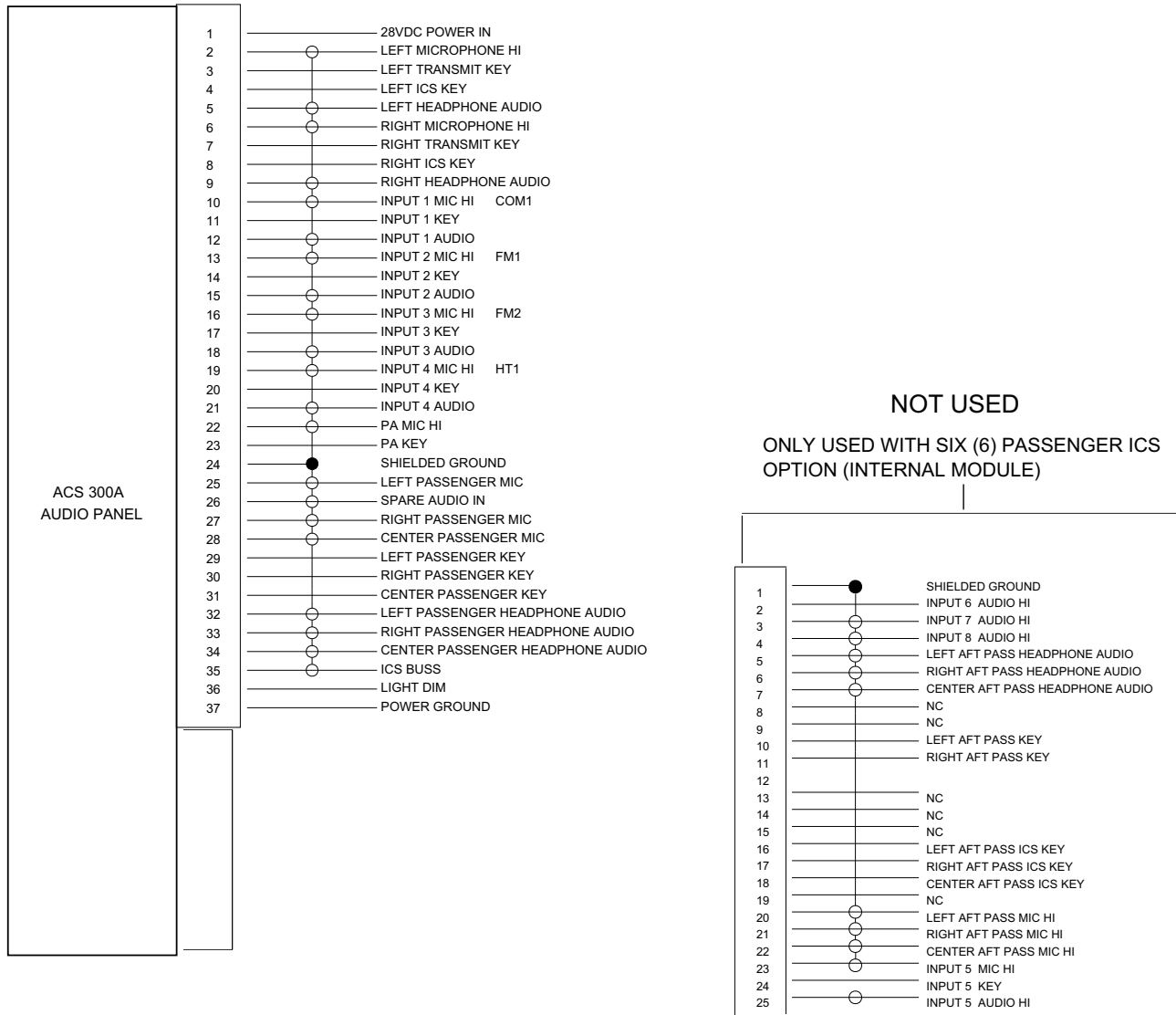

The ACS 300A wiring harness should be constructed of Tefzel aircraft wire (M22759/16 grade). Power and ground wires should be 18 or 20 AWG, and all other wires may be 22 AWG. Shielded wires should be used where noted. Adequate protection against wear and chafing should be taken by using a braided cable sleeving or jacket. Before completing installation, verify that all cable connector pins are seated properly and that the connector is securely mounted to the unit mating connector.

Pre-fabricated cable harnesses are available from Air Comm to expedite installation — consult our sales department for details.

NOTE: Pins noted NC = No Connection.

ACS 300A-100 Installation and Operations Manual Front Panel Controls

(See Figure 1 — Page 8 for pictorial)

■ Description

The ACS300A-100 Dual Audio Mixer Panel is a compact, lightweight unit which provides full audio control and ICS support for Pilot and Co-pilot or observer positions in the aircraft. It has the capability to provide each user with 6 receive audio selections, 6 transmitter selections, Normal and HOT (Hands Free) ICS, and full headphone audio and ICS volume control. In addition, an internal expansion slot accepts a plug-in module (optional) which can give the unit an additional 6 positions of ICS capability, 2 of which also have TX capability.

■ 1- Norm - Emer Switch

This switch controls the operation of the audio panel in the event of an audio amplifier failure. In the “up” position (NORM) the audio panel is in normal operating mode. In the “down” position (EMER) the unit is in the emergency mode. During Emergency operation, with a receive audio switch in the "down" position the mic select rotary switch selects the mic, key, and unamplified audio in the event of an audio amplifier failure. The side in emergency mode will not have incoming ICS.

■ 2 - Receive Audio Select-Mute Switches

Normal operation - In the “up” position the audio selected is summed with any other audios selected into the headphone amplifier. It also selects or mutes cross side tone. In the “down” position the audio selected is muted. Cross side tone is also muted.

Emergency operation - In the "down" position the mic select rotary switch selects the mic, key, and unamplified audio in the event of an audio amplifier failure. The side in emergency mode will not have incoming ICS.

■ 3 - Volume Controls

These concentric knobs adjust headphone volume. The larger one adjusts the radio volume while the smaller one adjusts the intercom (ICS) volume. Clockwise rotation increases the volume - counter clockwise rotation decreases the volume. To set volume, transmit on the radio and set the side tone level slightly on the low side so you will have a tendency to talk up and have higher modulation. Then set the radio volume for comfortable listening. In the event of excessive or inadequate receiver volume the pots located on the rear of the unit may be adjusted for the proper level. (See Figure 2 on page 8).

ACS 300A-100 Installation and Operations Manual

Front Panel Controls

(See Figure 1 — Page 8 for pictorial)

■ **4 - Lighting**

The audio panel is lit by two 28V lamps which provide night time visibility for all panel legends. They can be connected to a dimmer bus for adjustment. The lamps can be changed from the front panel by unscrewing the light filter cap. The lamp part number is 327, and is readily available from the factory and most electronic component suppliers.

■ **5 - Mic Selector**

This rotary switch performs three functions simultaneously. It (a) connects the mic to the selected transmitter (b) selects the associated keyline, and (c) selects the associated audio (if not already selected using the audio select-mute switch). The audio selected also allows for cross side tone if the other mic select switch has selected the same transmitter.

■ **6 - Transmit Indicator**

When the transmit key is activated this indicator lights up show that the audio panel is in the transmit mode.

■ **7 - ICS Switch**

This switch selects the ICS mode. In the “up” position (ICS) each side of the audio panel is connected to the common ICS bus. This enables each side to communicate with the other side when their respective ICS PTT switches are keyed.

In the “center” position (OFF), the ICS bus is disconnected and both sides are isolated.

The ICS switch also provides for “Hands Free” operation. In the “down” position (HOT ICS) , both headphone mics are active and signals are fed into the ICS bus without having to key the respective ICS PTT switches.

ACS 300A-100 Installation and Operations Manual

Front and Rear Panel Controls

■ Figure 1 - Front Panel Controls

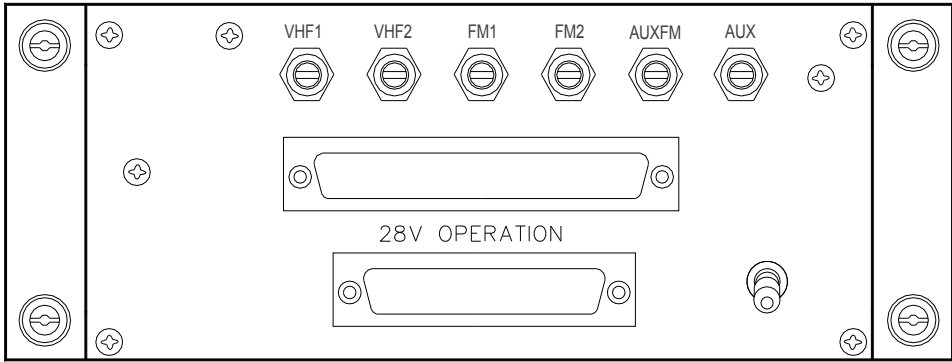
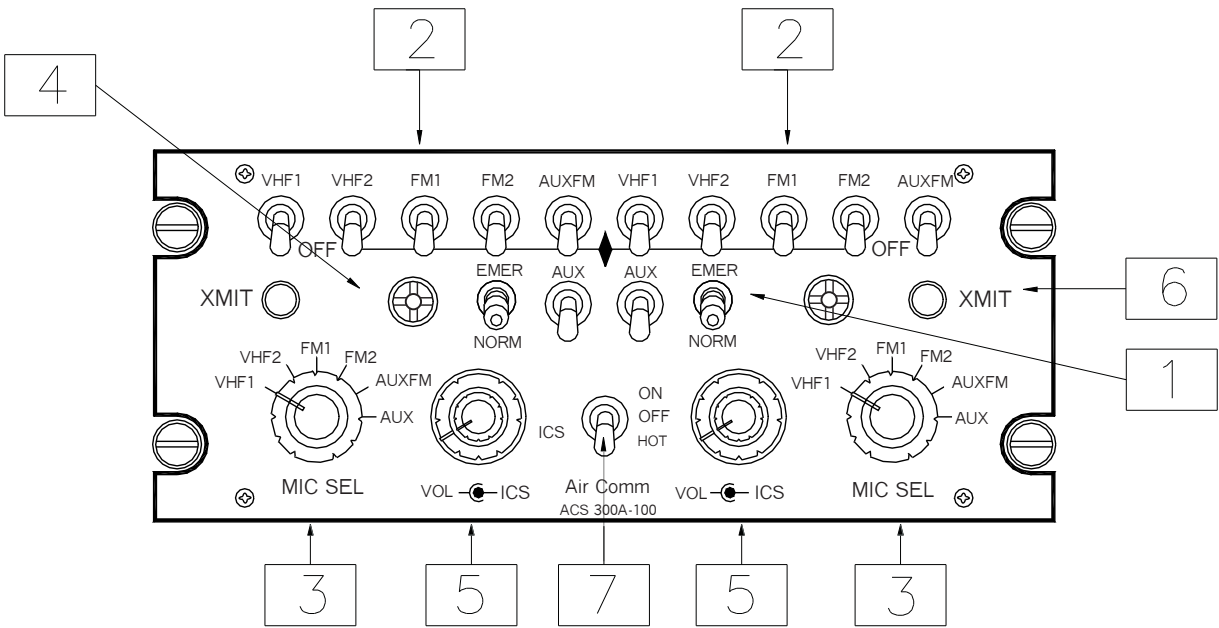

■ Figure 2 - Rear Panel Adjustment

ACS 300A-100 Installation and Operations Manual

Instruction for Continued Airworthiness

■ **GENERAL DESCRIPTION:**

The Audio Mixer Panel consists of a Dzus mounting located in the cockpit or cabin area which provides access to multiple radios for transmitting and receiving. It also provides intercom, and keyed between other audio mixer panels or slave units located elsewhere in the aircraft.

■ **PURPOSE:**

To provide instructions for the maintenance and inspection of the Air Comm Systems, Inc. Model ACS-300 Series Audio Mixer Panels.

This Manual provides instructions supplementing the aircraft maintenance manual. These instructions only supersede the aircraft manual in the indicated areas.

■ **OPERATIONAL CHECK:**

The Audio Mixer Panel should be checked prior to first flight each day per current operations manual.

■ **MAINTENANCE:**

Check security and condition of Dzus mounted panel(s), check associated wiring harness at periodic inspections such as annual/100 hour IAW FAR43 Appendix D(i).

■ **On Condition.**

Send Audio Mixer Panel(s) to qualified repair facility for any repairs. Contact Air Comm Systems, Inc. Phone 951-677-0101 or FAX 951-677-0701 for more information.

ACS 300A-100 Installation and Operations Manual Warranty Information

■ Limited Warranty Information

Air Comm Systems, Inc. warrants each new product to be free from defective material and workmanship and agrees to remedy any defect or to furnish a new part in exchange for any defective unit provided an examination discloses such defect occurred under normal use and service, and provided the defective unit is delivered to us, with transportation charges prepaid, within 1 year from the date of acceptance of equipment by the owner. Each unit required and claimed defective must be returned to:

Air Comm Systems, Inc.
37610 Sky Canyon Dr., Hangar 51
Murrieta, CA 92563
Ph: 951-677-0101
Fx: 951-677-0701
Info@AirCommSystems.com

This warranty does not extend to any products which have been subjected to misuse, neglect, accident, or in violation of instructions furnished, nor does it extend to units which have been repaired or altered outside of our factory except where such repairs are specifically authorized in writing by us.

This warranty is in lieu of all other warranties expressed or implied, and no representative or person is authorized to assume for us any other liability in connection with the sale of our products.